

EO2 Stacker Assembly

1. Carefully Remove the protection film from the stacker base and stacker backstop.
2. Peel the protection film off the adhesive tape attached to the stacker backstop.
3. Align the stacker backstop with the cut out in the stacker base before attaching. Note, the lip of the backstop adheres to the bottom of the stacker base. Flip the stacker over and firmly press down to secure the backstop to the base.

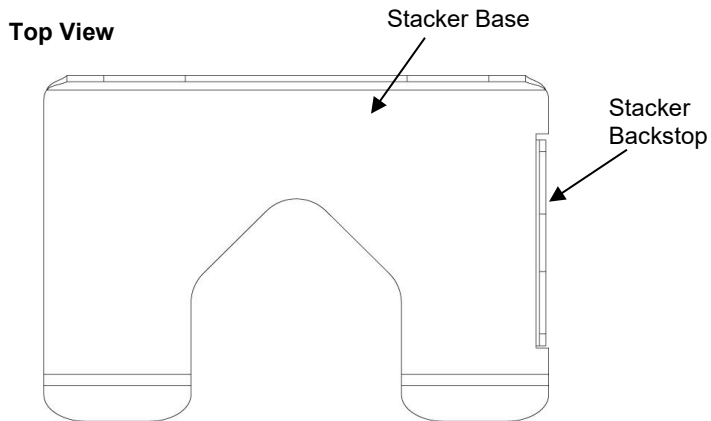

Assembled Stacker

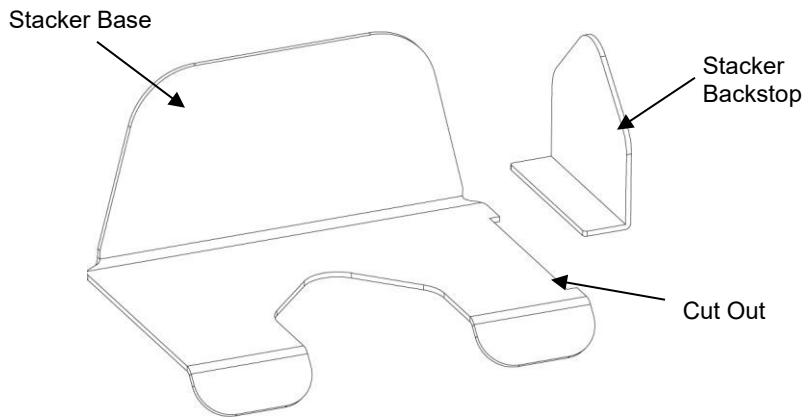